

C300 2.5-Inch SATA NAND Flash SSD

MTFDDACxxxMAG

Features

- Micron® MLC NAND Flash
- RoHS-compliant package
- SATA 6 Gb/s interface
- ATA modes supported
 - PIO mode 3, 4
 - Multiword DMA mode 0, 1, 2
 - Ultra DMA mode 0, 1, 2, 3, 4, 5, 6
- Industry-standard, 512-byte sector size support
- Hot-plug capable
- Native command queuing support with 32 command slot support
- ATA-8 command set compliant
- ATA security feature command set and password login support
- Secure erase (data page) command set: fast and secure erase (clear, sanitize)
- Self-monitoring, analysis, and reporting technology (SMART) command set
- Performance^{1, 2}
 - PCMark® Vantage (HDD test suite score): 45,000 [40,000 for 64GB] (SATA 6 Gb/s); 35,000 [32,000 for 64GB] (SATA 3 Gb/s)
 - Sequential READ: up to 355 MB/s (SATA 6 Gb/s), up to 265 MB/s (SATA 3 Gb/s)
 - Sequential WRITE: up to 215 MB/s (75 MB/s for 64GB drive; 140 MB/s for 128GB drive)
 - Random 4k READ: up to 60,000 IOPS (SATA 6 Gb/s), up to 50,000 IOPS (SATA 3 Gb/s)
 - Random 4k WRITE: up to 45,000 IOPS (15,000 IOPS for 64GB drive; 30,000 IOPS for 128GB drive)
 - READ latency: 55µs (TYP SATA 6 Gb/s), 70µs (TYP SATA 3 Gb/s)
 - WRITE latency: 60µs (TYP SATA 6 Gb/s), 95µs (TYP SATA 3 Gb/s)
- Reliability
 - MTBF: 1.2 million device hours
 - 3-year warranty
 - Static and dynamic wear leveling
 - Field-upgradable firmware
 - Uncorrectable bit error rate (UBER): <1 sector per 10¹⁵ bits read
 - Low power consumption
- Endurance: Total bytes written (TBW) – 72TB
- Mechanical
 - SATA connector: 5V ±5%
 - 2.5-inch drive: 100.45mm x 69.85mm x 9.5mm
 - Weight: 75g (MAX)
- Capacity³ (unformatted): 64GB, 128GB, 256GB
- Operating temperature: Commercial (0°C to +70°C)

- Notes:
1. Typical I/O performance numbers as measured using Iometer with a queue depth of 32 and write cache enabled.
 2. 4K transfers used for READ/WRITE latency values.
 3. 1GB = 1 billion bytes; formatted capacity is less.

Part Numbering Information

Micron's RealSSD™ C300 SSD is available in different configurations and densities. Visit www.micron.com for a list of valid part numbers.

Figure 1: Part Number Chart

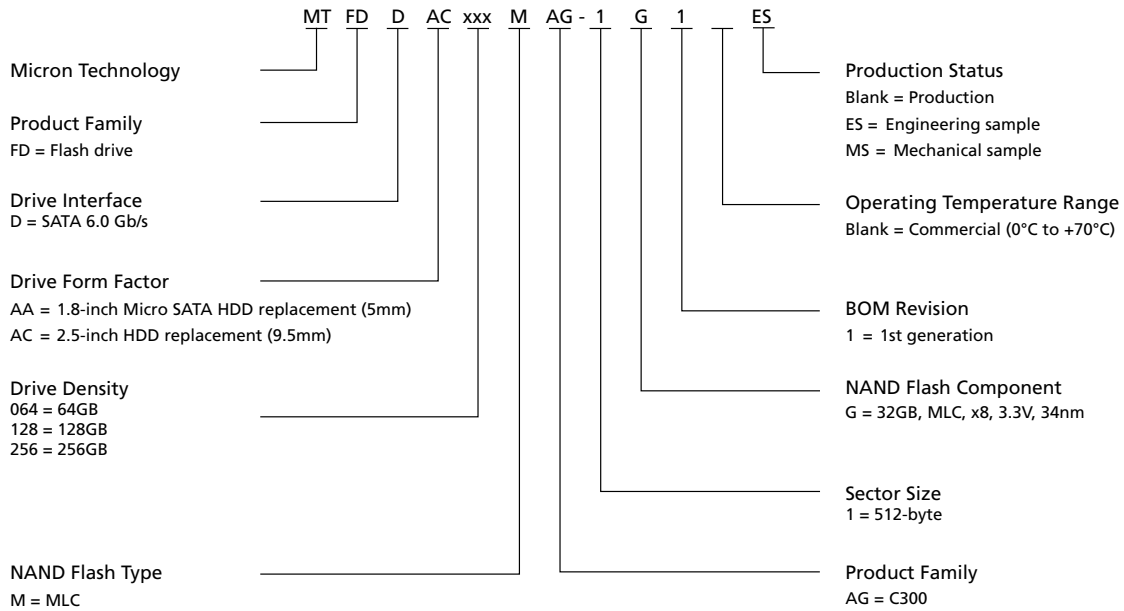

General Description

Micron’s RealSSD™ solid state drive (SSD) uses a single-chip controller with a SATA interface on the system side and n-channels of Micron NAND Flash internally. Packaged in an HDD replacement enclosure, the SSD integrates easily in existing storage infrastructures.

The SSD is designed to use the SATA interface efficiently during both READs and WRITES while delivering bandwidth-focused performance. SSD technology enables enhanced boot times, faster application load times, reduced power consumption, and extended reliability.

Figure 2: Functional Block Diagram

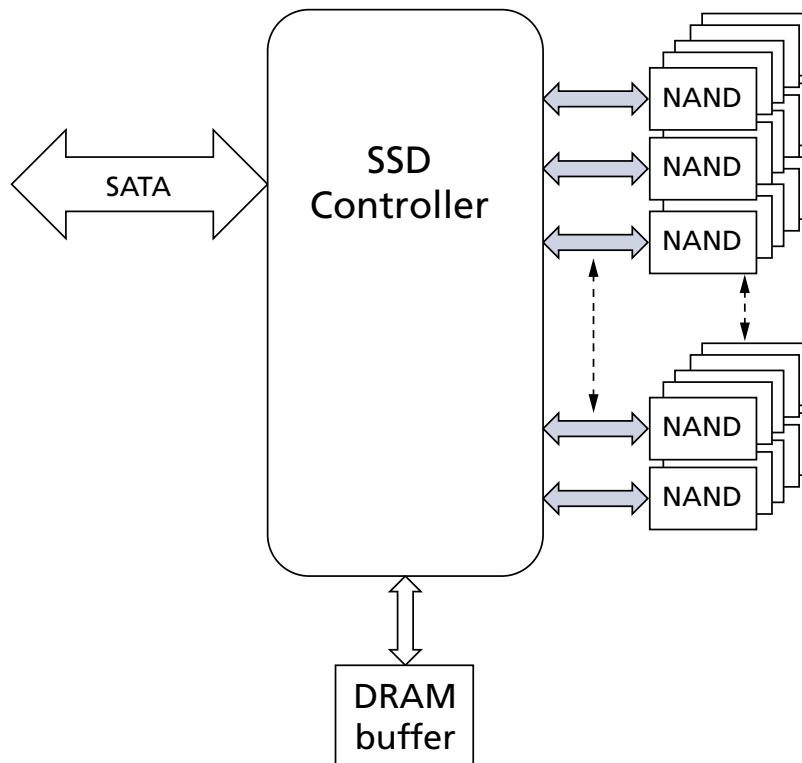

Architecture

The 300-series SSD is a NAND Flash storage device. A SATA 6 Gb/s interface connects to the SSD externally and communicates with the controller. The controller manages data transfers to and from the NAND Flash array.

Table 1: C300 Configurations

Unformatted Disk Density	NAND Flash Process	NAND Flash Density	Package Count	Die per BGA Package
64GB	34nm	32Gb	16	1
128GB	34nm	32Gb	16	2
256GB	34nm	32Gb	16	4

Logical Block Address Configuration

The drive is set to report the number of logical block addresses (LBA) that will ensure sufficient storage space for the specified density. Standard LBA settings, based on the IDEMA standard (LBA1-02), are shown below.

Table 2: Standard LBA Settings

Drive Size ¹	Total LBAs		Max LBA		User Available Bytes
	Decimal	Hexadecimal	Decimal	Hexadecimal	(Unformatted)
64GB	125,045,424	7740AB0	125,045,423	7740AAF	68,719,476,736
128GB	250,069,680	EE7C2B0	250,069,679	EE7C2AF	128,035,676,160
256GB	500,118,192	1DCF32B0	500,118,191	1DCF32AF	256,060,514,304

Note: 1. 1GB = 1,000,000,000 bytes.

Table 3: 2.5-Inch Nominal Dimensions and Weight

	Value	Unit
Height	9.5	mm
Width	69.85	mm
Length	100.45	mm
Unit weight	75	g

Interface Connectors

The SATA signal segment interface cable has four conductors and three ground connections. As shown in Package Dimensions, the cable includes a 7-pin signal segment and a 9-pin power segment arranged in a single row with a 1.27mm (0.050in) pitch.

Table 4: SATA Signal Segment Pin Assignments

Signal Name	Type	Description
S1	GND	Ground
S2	A	Differential signal pair A and A#
S3	A#	
S4	GND	Ground
S5	B#	Differential signal pair B and B#
S6	B	
S7	GND	Ground

Table 5: 2.5-Inch SATA Power Segment Pin Assignments

Pin#	Signal Name	Description
P1	V33	No connect
P2	V33	No connect
P3	V33	No connect
P4	GND	Ground
P5	GND	Ground
P6	GND	Ground
P7	V5	5V power, precharge
P8	V5	5V power
P9	V5	5V power
P10	GND	Ground
P11	DAS ¹	Device activity signal
P12	GND	Ground
P13	V12	No connect
P14	V12	No connect
P15	V12	No connect

Note: 1. The DAS signal may be optionally connected to GND if an LED is not being used.

Figure 3: SSD Interface Connections

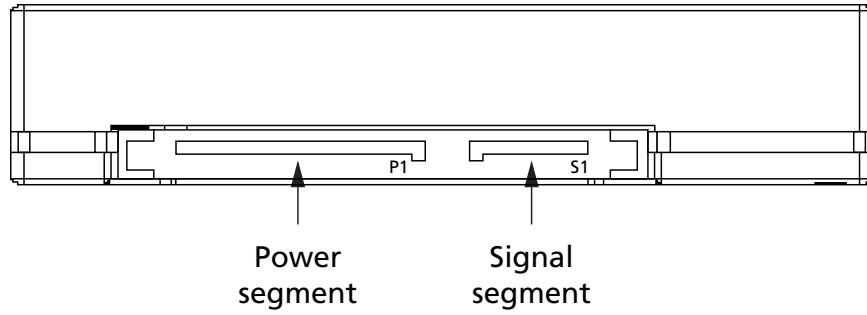

Device ID

Table 6: IDENTIFY Device ID

- F = The content of the word is fixed and does not change
- V = The content of the word is variable and may change depending on the state of the device or the commands executed by the device
- X = The content of the word may be fixed or variable
- R = The content of the word is reserved and shall be zero

Word	Bit(s)	Setting	Default Value	Description
0	15	F	0b	0 = ATA device
	14–8	X	X	Retired
	7	F	0b	0 = Non-removable media device
	6–3	X	X	Don't Care
	2	V	0/1b	1 = IDENTIFY DEVICE data incomplete
	1	X	X	Retired
	0	F	0b	Reserved
1	15–0	X	X	Number of logical cylinders (obsolete)
2	15–0	V	X	Specific configuration (obsolete)
3	15–0	X	X	Number of logical heads (obsolete)
4–5	31–0	X	X	Retired
6	15–0	X	X	Number of sectors per logical head
7–8	31–0	V	X	Reserved
9	15–0	X	X	Retired
10–19	159–0	F	Varies	Serial number (20 ASCII characters)
20–22	47–0	X	X	Retired/Obsolete
23–26	63–0	F	Varies	Firmware revision (8 ASCII characters)
27–46	319–0	F	Varies	Model number (40 ASCII characters)
47	15–8	F	80h	80h
	7–0	F	10h	00h = Reserved 01h-FFh = Number of sectors transferred per interrupt on R/W MULTIPLE cmds
48	15–0	F	4000h	Reserved
49	15–14	R	00b	Reserved for IDENTIFY PACKET DEVICE cmd
	13	F	1b	1 = Standby timer values as specified in ATA/ATAPI - 7 support 0 = Standby timer values shall be managed by the device
	12	R	0b	Reserved for IDENTIFY PACKET DEVICE cmd
	11	F	1b	1 = IORDY support 0 = IORDY may be supported
	10	F	1b	1 = IORDY may be disabled
	9	F	1b	1 = LBA support
	8	F	1b	1 = DMA support
	7–0	X	X	Retired

Table 6: IDENTIFY Device ID (Continued)

- F = The content of the word is fixed and does not change
- V = The content of the word is variable and may change depending on the state of the device or the commands executed by the device
- X = The content of the word may be fixed or variable
- R = The content of the word is reserved and shall be zero

Word	Bit(s)	Setting	Default Value	Description
50	15	F	0b	Shall be cleared to 0
	14	F	1b	Shall be set to 1
	13–2	F	0h	Reserved
	1	X	X	Obsolete
	0	F	1b	1 = Device specific standby timer min value
51–52	31–0	X	X	Obsolete
53	15–3	R	0h	Reserved
	2	F	1b	1 = The fields reported in word 88 are valid 0 = The fields reported in word 88 are not valid
	1	F	1b	1 = The fields reported in words (70:64) are valid 0 = The fields reported in words (70:64) are not valid
	0	X	X	Obsolete
54	15–0	X	X	Number of current cylinders (obsolete)
55	15–0	X	X	Number of current heads (obsolete)
56	15–0	X	X	Numer of current sectors per track (obsolete)
57–58	31–0	X	X	Current capacity in sectors (obsolete)
59	15–9	F	0h	Reserved
	8	V	X	1 = Multiple sector setting is valid (Don't Care)
	7–0	V	X	xxh = Current setting for number of sectors per interrupt on R/W MULTIPLE cmds
60–61	31–0	F	Sect	Total number of user addressable sectors (28-bit address)
62	15–0	X	X	Obsolete
63	15–11	F	0h	Reserved
	10	V	0/1b	1 = Multiword DMA mode 2 is selected 0 = Multiword DMA mode 2 is not selected
	9	V	0/1b	1 = Multiword DMA mode 1 is selected 0 = Multiword DMA mode 1 is not selected
	8	V	0/1b	1 = Multiword DMA mode 0 is selected 0 = Multiword DMA mode 0 is not selected
	7–3	F	0h	Reserved
	2	F	1b	1 = Multiword DMA mode 2 and below is supported
	1	F	1b	1 = Multiword DMA mode 1 and below is supported
	0	F	1b	1 = Multiword DMA mode 0 is supported
64	15–2	F	0h	Reserved
	1–0	F	3h	PIO modes support

Table 6: IDENTIFY Device ID (Continued)

- F = The content of the word is fixed and does not change
- V = The content of the word is variable and may change depending on the state of the device or the commands executed by the device
- X = The content of the word may be fixed or variable
- R = The content of the word is reserved and shall be zero

Word	Bit(s)	Setting	Default Value	Description
65	15–0	F	78h	Minimum multiword DMA transfer cycle time per word in nanoseconds
66	15–0	F	78h	MFR recommended multiword DMA transfer cycle time per word in nanoseconds
67	15–0	F	78h	Minimum PIO transfer cycle time without IORDY flow control
68	15–0	F	78h	Minimum PIO transfer cycle time with IORDY flow control
69	15	F	0b	1 = CFAST Specification support
	14	F	1b	1 = Supports deterministic data in trimmed LBA range(s)
	13	X	X	1 = Supports long physical sector alignment error reporting control
	12	F	0b	1 = Supports DEVICE CONFIGURATION IDENTIFY (and) SET DMA cmds
	11	X	X	1 = Supports READ BUFFER DMA command
	10	X	X	1 = Supports WRITE BUFFER DMA command
	9	F	0b	1 = Supports SET MAX SET PASSWORD (and) SET MAX UNLOCK DMA cmds
	8	F	0b	1 = Supports DOWNLOAD MICROCODE DMA command
	7	F	0b	Reserved
	6	F	0b	1 = Supports optional ATA device 28-bit commands
	5	F	0b	1 = Supports deterministically zeroed data in trimmed LBA range(s)
4–0	F	0b	Reserved	
70–74	79–0	F	0h	Reserved
75	15–5	F	0h	Reserved
	4–0	F	1Fh	1Fh = NCQ device (1Fh = 32 - 1 [maximum queue depth support])

Table 6: IDENTIFY Device ID (Continued)

- F = The content of the word is fixed and does not change
- V = The content of the word is variable and may change depending on the state of the device or the commands executed by the device
- X = The content of the word may be fixed or variable
- R = The content of the word is reserved and shall be zero

Word	Bit(s)	Setting	Default Value	Description
76	15–13	F	0h	Reserved
	12	F	1b	1 = Supports NCQ priority information
	11	F	0b	1 = Supports unload while NCQ commands outstanding
	10	F	1b	1 = Supports PHY event counters
	9	F	1b	1 = Supports receipt of host-initiated power management requests (HIPM)
	8	F	1b	1 = Supports native command queuing (NCQ)
	7–4	F	0h	Reserved
	3	F	1b	1 = Supports SATA Gen-3 signaling speed (6 Gb/s)
	2	F	1b	1 = Supports SATA Gen-2 signaling speed (3 Gb/s)
	1	F	1b	1 = Supports SATA Gen-1 signaling speed (1.5Gb/s)
77	0	F	0b	Reserved
	15–4	F	0h	Reserved
	3–1	V	X	Indicates the Serial ATA PHY speed at which the device is currently communicating: 0 = Signaling speed not reported 1 = Gen-1 signaling speed of 1.5 Gb/s 2 = Gen-2 signaling speed of 3.0 Gb/s 3 = Gen-3 signaling speed of 6.0 Gb/s
78	0	F	1b	Shall be cleared to zero
	15–7	F	0h	Reserved
	6	F	1b	1 = Supports software settings preservation
	5	F	0b	Reserved
	4	F	0b	1 = Supports in-order data delivery
	3	F	1b	1 = Device supports initiating interface power management (DIPM)
	2	F	1b	1 = Supports DMA setup auto-activate optimization
	1	F	0b	1 = Supports nonzero buffer offsets in DMA setup FIS
0	F	0b	Reserved	

Table 6: IDENTIFY Device ID (Continued)

- F = The content of the word is fixed and does not change
- V = The content of the word is variable and may change depending on the state of the device or the commands executed by the device
- X = The content of the word may be fixed or variable
- R = The content of the word is reserved and shall be zero

Word	Bit(s)	Setting	Default Value	Description
79	15–7	F	0h	Reserved
	6	V	1b	1 = Software settings preservation enabled
	5	F	0b	Reserved
	4	V	0b	1 = In-order data delivery enabled
	3	V	0b	1 = Device initiating interface power management enabled
	2	V	0b	1 = DMA setup auto-activate optimization enabled
	1	V	0b	1 = Nonzero buffer offsets in DMA setup FIS enabled
	0	F	0b	Reserved
80	15–9	F	0h	Major version number reserved (future revisions)
	8	F	1b	Reserved for ATA/ATAPI-8 major version number
	7	F	1b	1 = Supports ATA/ATAPI-7 major version number
	6	F	1b	1 = Supports ATA/ATAPI-6 major version number
	5	F	1b	1 = Supports ATA/ATAPI-5 major version number
	4	F	1b	1 = Supports ATA/ATAPI-4 major version number
	3–1	X	X	Obsolete
	0	F	0b	Reserved
81	15–0	F	28h	Minor version number
82	15	X	X	Obsolete
	14	F	1b	1 = NOP command support
	13	F	1b	1 = READ BUFFER command support
	12	F	1b	1 = WRITE BUFFER command support
	11	X	X	Obsolete
	10	F	1b	1 = Host-protected area feature set support
	9	F	0b	1 = DEVICE RESET command support (ATAPI packet command)
	8	F	0b	1 = Service interrupt support
	7	F	0b	1 = Release interrupt support
	6	F	1b	1 = Look-ahead support
	5	F	1b	1 = Write cache support
	4	F	0b	1 = Packet command feature set support
	3	F	1b	1 = Mandatory power management feature set support
	2	F	0b	1 = Removable media feature set support
	1	F	1b	1 = Security mode feature set support
0	F	1b	1 = SMART feature set support	

Table 6: IDENTIFY Device ID (Continued)

- F = The content of the word is fixed and does not change
- V = The content of the word is variable and may change depending on the state of the device or the commands executed by the device
- X = The content of the word may be fixed or variable
- R = The content of the word is reserved and shall be zero

Word	Bit(s)	Setting	Default Value	Description
83	15	F	0b	Shall be cleared to 0
	14	F	1b	Shall be set to 1
	13	F	1b	1 = FLUSH CACHE EXT command support
	12	F	1b	1 = Mandatory FLUSH CACHE command support
	11	F	1b	1 = Device configuration overlay feature set support
	10	F	1b	1 = 48-bit address feature set support
	9	F	0b	1 = Automatic acoustic management feature set support
	8	F	1b	1 = SET MAX security extension support
	7	F	0b	1 = Address offset reserved area boot mode support
	6	F	X	1 = SET FEATURES subcommand required by HDD will be non-op to an SSD
	5	F	0b	1 = Power-up in standby feature set support
	4	F	0b	1 = Removable media status notification feature set support
	3	F	1b	1 = Advanced power management feature set support
	2	F	0b	1 = CFA feature set support
	1	F	0b	1 = READ/WRITE DMA QUEUED support
0	F	1b	1 = DOWNLOAD MICROCODE command support	

Table 6: IDENTIFY Device ID (Continued)

- F = The content of the word is fixed and does not change
- V = The content of the word is variable and may change depending on the state of the device or the commands executed by the device
- X = The content of the word may be fixed or variable
- R = The content of the word is reserved and shall be zero

Word	Bit(s)	Setting	Default Value	Description
84	15	F	0b	Shall be cleared to 0
	14	F	1b	Shall be set to 1
	13	F	1b	1 = IDLE IMMEDIATE with UNLOAD FEATURE support
	12	F	X	Reserved for technical report INCITS TR-37-2004 (TLC)
	11	F	X	Reserved for technical report INCITS TR-37-2004 (TLC)
	10	F	0b	1 = URG bit support for WRITE STREAM DMA EXT (and) WRITE STREAM EXT
	9	F	0b	1 = URG bit support for READ STREAM DMA EXT (and) READ STREAM EXT
	8	F	X	1 = 64-bit worldwide name support
	7	F	0b	1 = WRITE DMA QUEUED FUA EXT command support
	6	F	1b	1 = WRITE DMA FUA EXT (and) WRITE MULTIPLE FUA EXT commands support
	5	F	1b	1 = General purpose logging feature set support
	4	F	0b	1 = Streaming feature set support
	3	F	0b	1 = Media card passthrough command feature set support
	2	F	0b	1 = Media serial number support
	1	F	1b	1 = SMART self-test support
0	F	1b	1 = SMART error logging support	

Table 6: IDENTIFY Device ID (Continued)

- F = The content of the word is fixed and does not change
- V = The content of the word is variable and may change depending on the state of the device or the commands executed by the device
- X = The content of the word may be fixed or variable
- R = The content of the word is reserved and shall be zero

Word	Bit(s)	Setting	Default Value	Description
85	15	X	X	Obsolete
	14	F	1b	1 = NOP command enabled
	13	F	1b	1 = READ BUFFER command enabled
	12	F	1b	1 = WRITE BUFFER command enabled
	11	X	X	Obsolete
	10	V	1b	1 = Host-protected area feature set enabled
	9	F	0b	1 = DEVICE RESET command enabled (ATAPI packet command)
	8	V	0b	1 = SERVICE interrupt enabled
	7	V	0b	1 = Release interrupt enabled
	6	V	1b	1 = Look-ahead enabled
	5	V	1b	1 = Write cache enabled
	4	F	0b	1 = Packet command feature set enabled
	3	F	1b	1 = Power management feature set enabled
	2	F	0b	1 = Removable media feature set enabled
	1	V	0b	1 = Security mode feature set enabled
0	V	1b	1 = SMART feature set enabled	
86	15	F	1b	1 = Words 120 and 119 are valid
	14	F	0b	Reserved
	13	F	1b	1 = FLUSH CACHE EXT command supported
	12	F	1b	1 = Mandatory FLUSH CACHE command support
	11	F	1b	1 = Device configuration overlay feature set support
	10	F	1b	1 = 48-bit address feature set support
	9	V	0b	1 = Automatic acoustic management feature set enabled
	8	F	0b	1 = SET MAX security extension enabled by SET MAX SET PASSWORD
	7	F	0b	1 = Address offset reserved area boot mode active
	6	F	X	1 = SET FEATURES subcommand required on HDD and is non-pp for an SSD
	5	V	0b	1 = Power-up in standby feature set enabled
	4	V	0b	1 = Removable media status notification feature set enabled
	3	V	X	1 = Advanced power management feature set enabled
	2	F	0b	1 = CFA feature set enabled
	1	F	0b	1 = READ/WRITE DMA QUEUED support
0	F	1b	1 = DOWNLOAD MICROCODE command support	

Table 6: IDENTIFY Device ID (Continued)

- F = The content of the word is fixed and does not change
- V = The content of the word is variable and may change depending on the state of the device or the commands executed by the device
- X = The content of the word may be fixed or variable
- R = The content of the word is reserved and shall be zero

Word	Bit(s)	Setting	Default Value	Description
87	15	F	0b	Shall be cleared to 0
	14	F	1b	Shall be set to 1
	13	F	1b	1 = IDLE IMMEDIATE with UNLOAD FEATURE support (default)
	12	F	X	Reserved for technical report INCITS TR-37-2004 (TLC)
	11	F	X	Reserved for technical report INCITS TR-37-2004 (TLC)
	10	F	0b	1 = URG bit for WRITE STREAM DMA EXT (and) WRITE STREAM EXT (sup. Dflt.)
	9	F	0b	1 = URG bit for READ STREAM DMA EXT (and) READ STREAM EXT (sup. Dflt.)
	8	F	X	1 = 64-bit worldwide name support (default)
	7	F	0b	1 = WRITE DMA QUEUED FUA EXT command support (default)
	6	F	1b	1 = WRITE DMA FUA EXT (and) WRITE MULTIPLE FUA EXT cmds support (default)
	5	F	1b	1 = General purpose logging feature set support (default)
	4	V	0b	1 = Streaming feature set support (default)
	3	V	0b	1 = Media card passthrough command feature set support (default)
	2	V	0b	1 = Media serial number support (default)
	1	F	1b	1 = SMART self-test support (default)
0	F	1b	1 = SMART error logging support (default)	

Table 6: IDENTIFY Device ID (Continued)

- F = The content of the word is fixed and does not change
- V = The content of the word is variable and may change depending on the state of the device or the commands executed by the device
- X = The content of the word may be fixed or variable
- R = The content of the word is reserved and shall be zero

Word	Bit(s)	Setting	Default Value	Description
88	15	F	0b	Reserved
	14	V	0/1b	1 = Ultra DMA mode 6 is selected 0 = Ultra DMA mode 6 is not selected
	13	V	0/1b	1 = Ultra DMA mode 5 is selected 0 = Ultra DMA mode 5 is not selected
	12	V	0/1b	1 = Ultra DMA mode 4 is selected 0 = Ultra DMA mode 4 is not selected
	11	V	0/1b	1 = Ultra DMA mode 3 is selected 0 = Ultra DMA mode 3 is not selected
	10	V	0/1b	1 = Ultra DMA mode 2 is selected 0 = Ultra DMA mode 2 is not selected
	9	V	0/1b	1 = Ultra DMA mode 1 is selected 0 = Ultra DMA mode 1 is not selected
	8	V	0/1b	1 = Ultra DMA mode 0 is selected 0 = Ultra DMA mode 0 is not selected
	7	F	0b	Reserved
	6	F	X	1 = Ultra DMA mode 6 and below supported
	5	F	1b	1 = Ultra DMA mode 5 and below supported
	4	F	1b	1 = Ultra DMA mode 4 and below supported
	3	F	1b	1 = Ultra DMA mode 3 and below supported
	2	F	1b	1 = Ultra DMA mode 2 and below supported
	1	F	1b	1 = Ultra DMA mode 1 and below supported
	0	F	1b	1 = Ultra DMA mode 0 support
89	15–0	F	1h	Time required; Security erase unit complete
90	15–0	F	1h	Time required; Enhanced security erase complete
91	15–0	V	FEh	Current advanced power management value
92	15–0	V	0h or FFFFh	Master password revision code
93	15–0	V	0h	Cleared to 0s if Serial ATA
94	15–8	V	X	Vendor's recommended acoustic management value
	7–0	V	0h	Current auto acoustic management value
95	15–0	F	0h	Stream minimum request size
96	15–0	F	0h	Streaming transfer time – DMA
97	15–0	F	0h	Streaming access latency – DMA and PIO
98–99	31–0	F	0h	Streaming performance granularity
100–103	63–0	V	LBA	Maximum user LBA for 48-bit address feature set

Table 6: IDENTIFY Device ID (Continued)

- F = The content of the word is fixed and does not change
- V = The content of the word is variable and may change depending on the state of the device or the commands executed by the device
- X = The content of the word may be fixed or variable
- R = The content of the word is reserved and shall be zero

Word	Bit(s)	Setting	Default Value	Description
104	15-0	F	0h	Streaming transfer time – PIO
105	15-0	F	X	Maximum supported number of 512-byte blocks containing LBA range entries per DATA SET MANAGEMENT command
106	15	F	0b	Shall be cleared to 0
	14	F	1b	Shall be set to 1
	13	F	0b	1 = Device has multiple logical sectors per physical sector
	12	F	0b	1 = Device logical sector size > 256 words 0 = Device logical sector size is 256 words
	11-4	F	0h	Reserved
	3-0	F	0h	2 ^x logical sectors per physical sector
107	15-0	F	0h	Manufacturer's ISO-7779 acoustic testing interseek delay in microseconds
108	15-12	F	5h	NAA (3:0)
	11-0	F	Ah	IEEE OUI (23:12)
109	15-4	F	75h	IEEE OUI (11:0)
	3-0	F	X	Unique ID (35:32)
110	15-0	F	X	Unique ID (31:16)
111	15-0	F	X	Unique ID (15:0)
112-115	63-0	F	0h	Reserved for WWN extension to 128 bits
116	15-0	F	0h	Reserved
117-118	31-0	F	0h	Words per logical sector (valid if word 106 bit 12 = 1)
119	15	F	0b	Shall be cleared to 0
	14	F	1b	Shall be set to 1
	13-8	F	0h	Reserved
	7	X	X	1 = Extended power condition idle timer is enabled
	6	F	0b	1 = Sense data reporting feature set is enabled
	5	F	0b	1 = Free-fall control feature set is enabled
	4	F	1b	1 = Segmented feature for DOWNLOAD MICROCODE support
	3	F	1b	1 = READ LOG DMA EXT (and) WRITE LOG DMA EXT command support
	2	F	1b	1 = WRITE UNCORRECTABLE EXT support
	1	F	1b	1 = Write-read-verify feature set support
	0	F	0b	Reserved for DT1825

Table 6: IDENTIFY Device ID (Continued)

- F = The content of the word is fixed and does not change
- V = The content of the word is variable and may change depending on the state of the device or the commands executed by the device
- X = The content of the word may be fixed or variable
- R = The content of the word is reserved and shall be zero

Word	Bit(s)	Setting	Default Value	Description
120	15	F	0b	Shall be cleared to 0
	14	F	1b	Shall be set to 1
	13–8	F	0h	Reserved
	7	X	X	1 = Extended power condition idle timer is enabled
	6	F	0h	1 = Sense data reporting feature set is enabled
	5	F	0b	1 = Free-fall control feature set is enabled
	4	F	1b	1 = Segmented feature for DOWNLOAD MICROCODE support
	3	F	1b	1 = READ LOG DMA EXT (and) WRITE LOG DMA EXT command support
	2	F	1b	1 = WRITE UNCORRECTABLE EXT support
	1	F	0h	1 = Write-read-verify feature set support
	0	F	0b	Reserved for DT1825
121–126	95–0	F	0h	Reserved
127	15–0	F	0h	Removable media bits
128	15–9	F	X	Security status bits
	8	V	X	1 = Security mode enabled
	7–6	R	X	Security status bits
	5	V	1b	1 = Enhanced security erase unit support
	4	V	X	1 = Security count is expired
	3	V	X	1 = Security frozen
	2	V	X	1 = Security locked
	1	V	X	1 = Security enabled
0	F	1h	1 = Security supported	
129–159	527–0	X	X	Vendor specific
160	15–0	F	0h	CFA power mode 1 bits
161–167	111–0	X	0h	Reserved
168	15–4	X	0h	Reserved
	3–0	F	DNFF	Device nominal form factor (DNFF) SSD nominal form factor: 2h for 3.5-inch 3h for 2.5-inch 4h for 1.8-inch 5h for < 1.8-inch

Table 6: IDENTIFY Device ID (Continued)

- F = The content of the word is fixed and does not change
- V = The content of the word is variable and may change depending on the state of the device or the commands executed by the device
- X = The content of the word may be fixed or variable
- R = The content of the word is reserved and shall be zero

Word	Bit(s)	Setting	Default Value	Description
169	15–1	X	0h	Reserved
	0	F	1b	1 = Trim bit of the DATA SET MANAGEMENT command is supported
170–175	95–0	X	0h	Reserved
176–205	479–0	V	0h	Current media serial number
206	15–12	F	X	Vendor specific
	11–6	F	0h	Reserved
	5	F	1b	SCT data tables support (action code 5)
	4	F	X	SCT features control support (action code 4)
	3	F	X	SCT error recovery control support (action code 3)
	2	F	X	SCT write same support (action code 2)
	1	F	X	SCT read/write long support (action code 1)
	0	F	X	SCT support (including SCT read status)
207–208	31–0	F	0h	Reserved
209	15	F	0b	Shall be cleared to 0
	14	F	1b	Shall be set to 1
	13–0	F	0h	Logical sector offset of the first logical sector within the first physical sector
210–211	31–0	F	X	Write-read-verify sector count mode 3 only
212–213	31–0	F	X	Verify sector count mode 2 only
214	15–12	F	0h	NV cache feature set version
	11–8	F	0h	NV cache power mode feature set version
	7–5	F	0h	Reserved
	4	F	0b	1 = NV cache feature set enabled
	3–2	F	0h	Reserved
	1	F	0b	1 = NV cache power mode feature set enabled
	0	F	0b	1 = NV cache power mode feature set support
215–216	31–0	F	0h	NV cache size in logical blocks (DWORD)
217	15–0	F	1h	Non-rotating media device
218	15–0	F	0h	Reserved

Table 6: IDENTIFY Device ID (Continued)

- F = The content of the word is fixed and does not change
- V = The content of the word is variable and may change depending on the state of the device or the commands executed by the device
- X = The content of the word may be fixed or variable
- R = The content of the word is reserved and shall be zero

Word	Bit(s)	Setting	Default Value	Description
219	15–8	F	0h	Reserved
	7–0	F	0h	NV cache option: device estimated time to ready in seconds
220	15–8	F	0h	Reserved
	7–0	F	X	Write-read-verify feature set current mode
221	15–0	F	0h	Reserved
222	15–12	F	1h	Transport major revision number (0h = not reported yet; 1h = SATA)
	11–5	F	1h	Reserved
	4	F	1b	1 = SATA Rev. 2.6 (0 = not reported yet)
	3	F	1b	1 = SATA Rev. 2.5 (0 = not reported yet)
	2	F	1b	1 = SATA II: extensions (0 = not reported yet)
	1	F	1b	1 = SATA 1.0a (0 = not reported yet)
223	15–0	F	0h or 21h	Transport minor revision number (0h = not reported yet; 21h = ATA8-AST)
				Reserved for CE-ATA
224–233	159–0	F	0h	Reserved for CE-ATA
234	15–0	F	01h	Minimum number of 512 byte units per DOWNLOAD MICRO-CODE command mode 3
235	15–0	F	FFh	Maximum number of 512 byte units per DOWNLOAD MICRO-CODE command mode 3
236–254	303–0	F	0h	Reserved
255	15–8	X	X	Checksum
	7–0	X	A5h	A5h = signature for ATA device

Commands

Table 7: Supported ATA Command Set

See ATA-7 standard for command details

Command Name	Command Code (hex)
CHECK POWER MODE	98h or E5h
DEVICE CONFIGURATION RESTORE	B1h/C0h
DEVICE CONFIGURATION FREEZE LOCK	B1h/C1h
DEVICE CONFIGURATION IDENTIFY	B1h/C2h
DEVICE CONFIGURATION SET	B1h/C3h
DOWNLOAD MICROCODE	92h
EXECUTE DEVICE DIAGNOSTIC	90h
FLUSH CACHE	E7h
FLUSH CACHE EXT	EAh
IDENTIFY DEVICE	ECh
IDLE	E3h or 97h
IDLE IMMEDIATE	E1h or 95h
INITIALIZE DEVICE PARAMETERS	91h
NOP	00h
READ BUFFER	E4h
READ DMA (with retry)	C8h
READ DMA (without retry)	C9h
READ DMA EXT	25h
READ FPDMA QUEUED	60h
READ LOG EXT	2Fh
READ MULTIPLE	C4h
READ MULTIPLE EXT	29h
READ NATIVE MAX ADDRESS	F8h
READ NATIVE MAX ADDRESS EXT	27h
READ SECTOR(S) EXT	24h
READ SECTOR(S) (with retry)	20h
READ SECTOR(S) (without retry)	21h
READ VERIFY SECTOR EXT	42h
READ VERIFY SECTOR(S) (with retry)	40h
SCT READ LONG	01h/01h
SCT WRITE LONG	01h/02h
SCT WRITE SAME	02h/0001h 02h/0002h 02h/0101h 02h/0102h
SCT RETURN ERROR RECOVERY CONTROL	030h/02h
SCT SET ERROR RECOVERY CONTROL	03h/01h

Table 7: Supported ATA Command Set (Continued)

See ATA-7 standard for command details

Command Name	Command Code (hex)
SCT SET FEATURE CONTROL	04h/01h
SCT RETURN FEATURE CONTROL	04h/02h
SCT RETURN FEATURE OPTION FLAG	04h/03h
SCT RETURN SCT DATA TABLE	05h/01h
SECURITY DISABLE PASSWORD	F6h
SECURITY ERASE PREPARE	F3h
SECURITY ERASE UNIT	F4h
SECURITY FREEZE LOCK	F5h
SECURITY SET PASSWORD	F1h
SECURITY UNLOCK	F2h
SEEK	7xh
SET FEATURES	EFh
SET MAX ADDRESS	F9h
SET MAX – FREEZE LOCK	F9h/04h
SET MAX – LOCK	F9h/02h
SET MAX ADDRESS EXT	37h
SET MULTIPLE MODE	C6h
SET MAX – SET PASSWORD	F9h/01h
SET MAX – UNLOCK	F9h/03h
SLEEP	E6h or 99h
SMART DISABLE OPERATIONS	B0h/D9h
SMART ENABLE OPERATIONS	B0h/D8h
SMART ENABLE/DISABLE AUTOSAVE	B0h/D2h
SMART EXECUTE OFF-LINE IMMEDIATE	B0h/D4h
SMART READ DATA	B0h/D0h
SMART READ LOG SECTOR	B0h/D5h
SMART RETURN STATUS	B0h/DAh
SMART WRITE LOG	B0h/D6h
STANDBY	E2h or 96h
STANDBY IMMEDIATE	E0h or 94h
WRITE BUFFER	E8h
WRITE DMA (with retry)	CAh
WRITE DMA (without retry)	CBh
WRITE DMA EXT	35h
WRITE DMA FUA EXT	3Dh
WRITE FPDMA QUEUED	61h
WRITE LOG EXT	3Fh

Table 7: Supported ATA Command Set (Continued)

See ATA-7 standard for command details

Command Name	Command Code (hex)
WRITE MULTIPLE	C5h
WRITE MULTIPLE EXT	39h
WRITE MULTIPLE FUA EXT	CEh
WRITE SECTOR(S) (with retry)	30h
WRITE SECTOR(S) EXT	34h
WRITE UNCORRECTABLE EXT	45h

Reliability

Micron's SSDs incorporate advanced technology for defect and error management. They use various combinations of hardware-based error correction algorithms and firmware-based static and dynamic wear-leveling algorithms.

Over the life of the SSD, uncorrectable errors may occur. An uncorrectable error is defined as data that is reported as successfully programmed to the SSD but when it is read out of the SSD, the data differs from what was programmed.

Table 8: Uncorrectable Bit Error Rate

Uncorrectable Bit Error Rate	Operation
<1 sector per 10 ¹⁵ bits read	READ

Mean Time Between Failures

Mean time between failures (MTBFs) for the SSD can be predicted based on the component reliability data using the methods referenced in the Telcordia SR-332 reliability prediction procedures for electronic equipment.

Table 9: MTBFs

Density	MTBF (Operating Hours)
64GB	1.2 million
128GB	1.2 million
256GB	1.2 million

Endurance

Endurance for the SSD can be predicted based on the usage conditions applied to the device, the internal NAND component cycles, the write amplification factor, and the wear-leveling efficiency of the drive. The table below shows the drive lifetime for each SSD density based on predefined usage conditions.

Table 10: Drive Lifetime

Density	Drive Lifetime (Total Bytes Written)
64GB	72TB
128GB	72TB
256GB	72TB

- Notes:
1. Total bytes written calculated with the drive 90% full.
 2. Access patterns are 50% sequential and 50% random and consist of the following: 5% are 4k; 5% are 8k; 10% are 16k; 10% are 32k; 35% are 64K; and 35% are 128k.
 3. GB/day can be calculated by dividing the total bytes written value by (365 × number of years). For example: 72TB/5 years/365 days = 40 GB/day for 5 years.

Electrical Characteristics

Table 11: SATA Typical Power Consumption¹

Density	Idle ³	Sleep ³	Standby ³	Erase	Read ²	Write ²	Unit
64GB	< 0.1	< 0.1	< 0.1	2.9	1.7	2.4	W
128GB	< 0.1	< 0.1	< 0.1	3.0	1.7	3.1	W
256GB	< 0.1	< 0.1	< 0.1	4.0	2.1	4.3	W

- Notes: 1. Data taken at 25°C using a 6 Gb/s SATA interface.
 2. IOMETER MAX transfer rate with 128KB transfer size.
 3. DIPM enabled.

Table 12: Absolute Maximum Ratings

Parameter/Condition	Symbol	Min	Max	Unit
Voltage input	V ₅	4.75	5.25	V
Operating temperature	T _A	0	70	°C
Non-operating temperature		-55	95	°C
Rate of temperature change		-	20	°C/hour
Relative humidity (noncondensing)		5	95	%

Stresses greater than those listed may cause permanent damage to the device. This is a stress rating only, and functional operation of the device at these or any other conditions above those indicated in the operational sections of this specification is not implied. Exposure to absolute maximum rating conditions for extended periods may affect reliability.

Table 13: Shock and Vibration

Parameter/Condition	Specification
Operating shock	1500 G/1.0ms
Operating vibration	2-500Hz at 3.1G

Table 14: Recommended Operating Conditions

Parameter/Condition	Symbol	Min	Typ	Max	Unit
Power supply voltage	V ₅	4.75	5.00	5.25	V
Ground supply voltage	GND	0	0	0	V

Compliance

Micron SSDs comply with the following:

- RoHS “green”
- CE (Europe): EN55022, 2006 Class B and EN55024, 1998 + A1: 2001 + A2:2003
- FCC: CFR Title 47, Part 15, ICES-003, all Class B
- UL (US): approval to UL-60950-1, 2nd Edition, 2007-03-27, IEC 60950-1:2005, 2nd Edition
- BSMI (Taiwan): approval to CNS 13438
- C-TICK (Australia, New Zealand): approval to AS/NZS CISPR22
- KCC RRL (Korea): approval to KCC MU2-C30025, KCC MU2-C30018 Class B
- W.E.E.E.
- TUV (Germany): approval to IEC60950/EN60950
- V_{CCI}

Package Dimensions

Figure 4: 2.5-Inch Package (Preliminary)

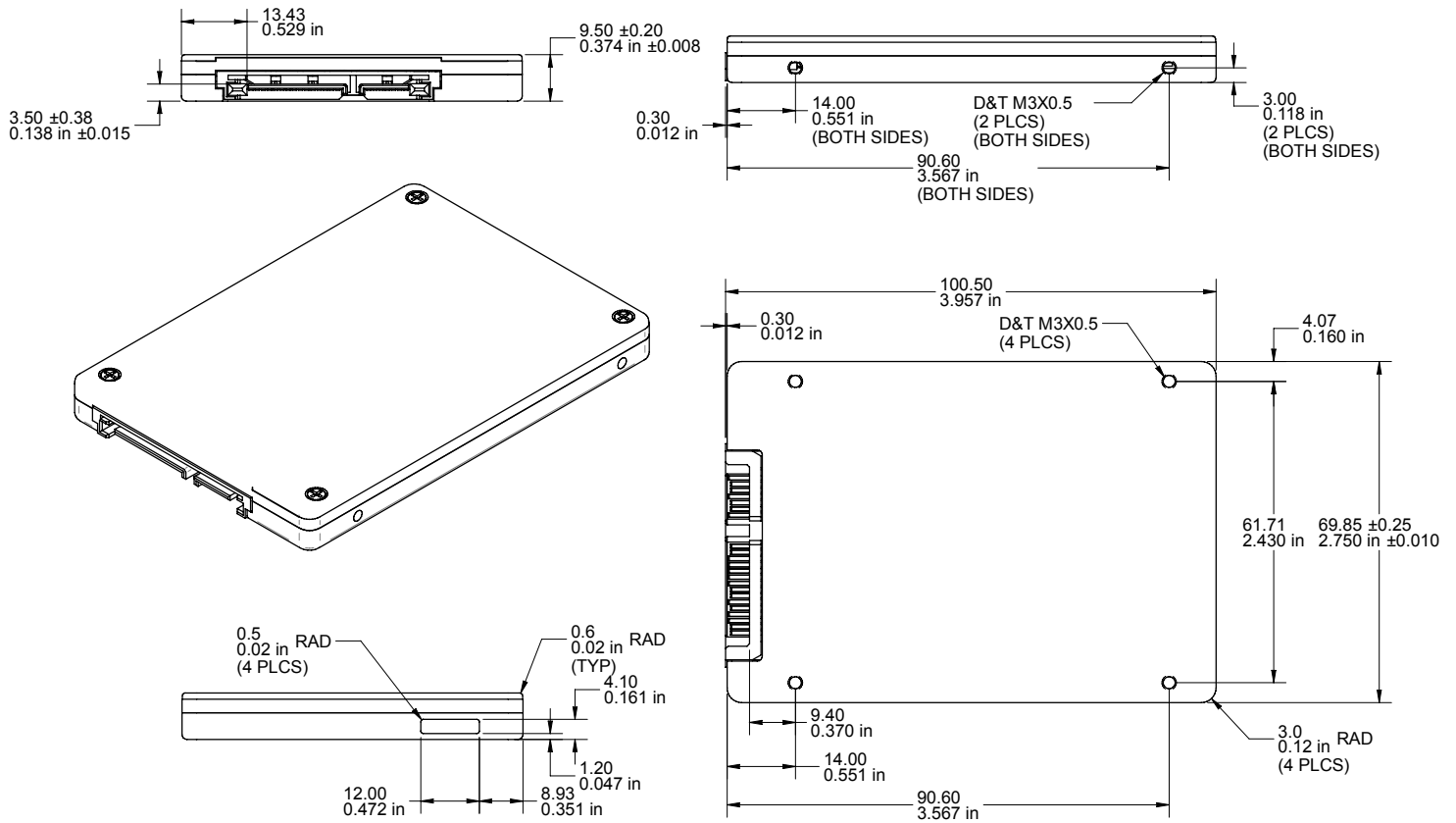

Note: 1. All dimensions are in millimeters.

References

- Serial ATA: High-speed serialized AT attachment, Serial ATA working group, available at www.sata-io.org
- Small Form Factor Specification SFF-8201, SFF-8223
- Electronic Industries Association Standard, EIA-720
- Serial ATA: High-speed serialized AT attachment, Serial ATA working group
- SFF documents
- EIA-720 document

8000 S. Federal Way, P.O. Box 6, Boise, ID 83707-0006, Tel: 208-368-3900
www.micron.com/productsupport Customer Comment Line: 800-932-4992
Micron and the Micron logo are trademarks of Micron Technology, Inc.

All other trademarks are the property of their respective owners.

This data sheet contains minimum and maximum limits specified over the power supply and temperature range set forth herein. Although considered final, these specifications are subject to change, as further product development and data characterization sometimes occur.