

CellularRAM® (PSRAM) Memory

An Ideal, Drop-In Replacement for SRAM

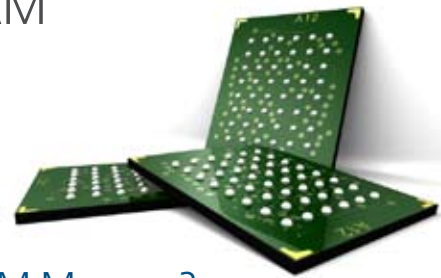

5 Reasons to Switch to CellularRAM Memory

Backward Compatibility

The same voltage range, package options, and ball assignments as standard SRAM make CellularRAM memory an easy decision—and an even easier transition.

Low Power Consumption

Low power dissipation in standby and active modes, plus PAR, TCR, and DPD, save power and boost battery life.

Higher Density

Provides a simple solution for expanding product functionality without adding design complexity.

Cost-Effective Design

DRAM architecture enables high densities to be manufactured at a relatively low cost without compromising quality or performance.

Design Compatibility

Gets you to market quicker thanks to reduced debug time and design reuse.

What is CellularRAM Memory?

If you design low-power applications that require cache or buffered memory, Micron's CellularRAM memory is the low-density, low-cost solution for you. It's a PSRAM memory device that merges the high throughput and relatively low cost of DRAM technology with SRAM pin-compatibility and hidden refresh operation. And its industry-standard, asynchronous interface and burst NOR Flash bus compatibility make it easy to design in.

What Makes CellularRAM Better?

With CellularRAM memory, you can boost the battery life in virtually any mobile or power-sensitive application that currently uses SRAM. It relies on several power-saving modes to consume less power than standard DRAM. Temperature-compensated refresh adjusts the refresh rate based on ambient temperatures. Partial-array refresh only uses power where and when it's needed. And deep power-down simply doesn't waste power when the device isn't in use.

CellularRAM also costs less than SRAM. Compare a bulky SRAM cell with six or more transistors, to a sleek DRAM (PSRAM) cell with just two. The difference is manufacturing costs. DRAM costs less to make, so we pass cost savings on to you—along with easy integration and high performance.

The advantages add up, making CellularRAM memory an ideal, drop-in SRAM replacement in low-power, cost-sensitive, and space-limited designs. Refer to the product and technical information on our Web site to choose the right PSRAM CellularRAM device for your application.

Configurations	Package	Speed	Deep Power-Down
Async/page	48-ball green VFPGA, KGD	55ns on 3.0V core, 70ns on 1.8V core	Yes
Async/page/burst	54-ball green VFPGA, KGD	104 MHz	Yes
Burst A/D MUX	KGD only	Contact factory	—

Note: All parts are available with partial-array refresh.

Enabler Support

Infineon
 TI – *Locosto*
 Qualcomm – *QSC 1000 series*
 Mediatek
 Philips/NXP

Async/Page Block Diagram

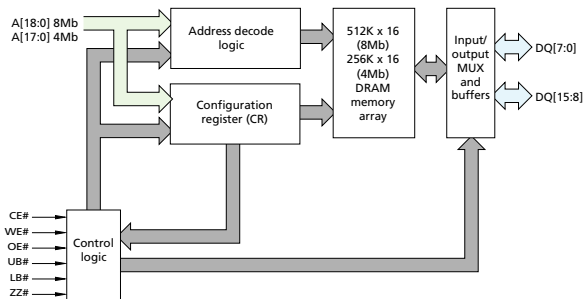

Async/Page/Burst Block Diagram

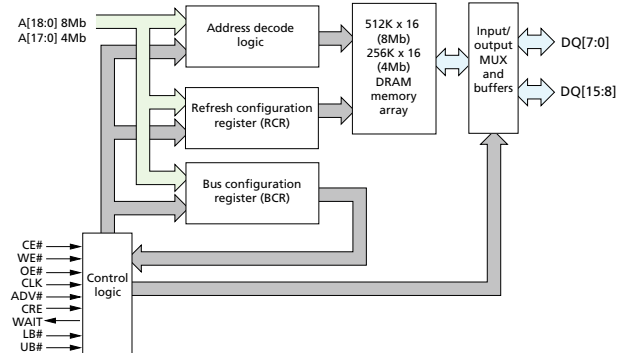

PSRAM Part Numbering

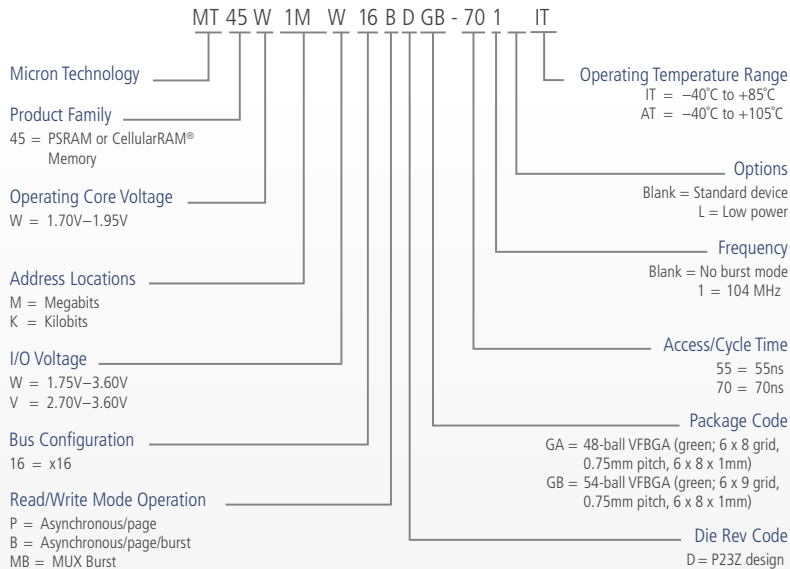

Micron Delivers...

Worldwide leadership in PSRAM with 30% market share

You Benefit By...

Utilizing steady product supply to meet operational objectives and customer demand

Micron Delivers...

Significant manufacturing scale

You Benefit By...

Receiving competitive pricing to lower cost and enhance margins

Micron Delivers...

Global engineering and technical resources

You Benefit By...

Employing a network of experienced talent dedicated to solving problems and delivering customer solutions

Micron Delivers...

A proven quality record

You Benefit By...

Lowering product failure rates while increasing marketability and brand reputation